



Every coating drum we manufacture is designed and engineered specifically to your product requirements.



Our shell-in-shell drum provides sanitary operation and simple cleaning for meat, dairy, and other process-specific applications.

Variable tilt frame assembly and product flight design exposes each piece of product to the application of liquid and dry coatings.

Custom product flight configuration reduces breakage.

#### Standard features

- 304 stainless steel shell-in-shell cylinder
- Washdown motor assembly with variable speed controller
- Variable tilt stainless steel frame assembly
- IP56 stainless steel control console
- Portable casters with brake assembly

#### Options

- Micro V-Belt or chain drive assembly
- 316 stainless steel drum cylinder
- Sanitary drain port at drum discharge
- Mist/dust collection shroud
- Insulated drum
- AC drive motor
- Easy Pull spray bar mount

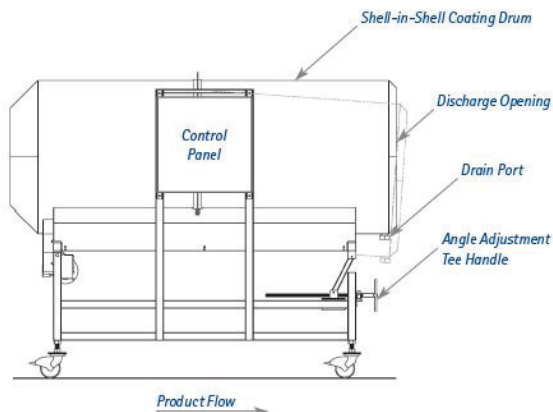

Constant improvement and engineering innovations mean these specifications can change without notice.